

SMX35



NEW

**AUTOMATIC
TYRE CHANGER WITH
LOCKING CAPACITY
UP TO 25"**

**SMONTAGOMME
AUTOMATICO
CON CAPACITÀ
DI BLOCCAGGIO
FINO A 25"**

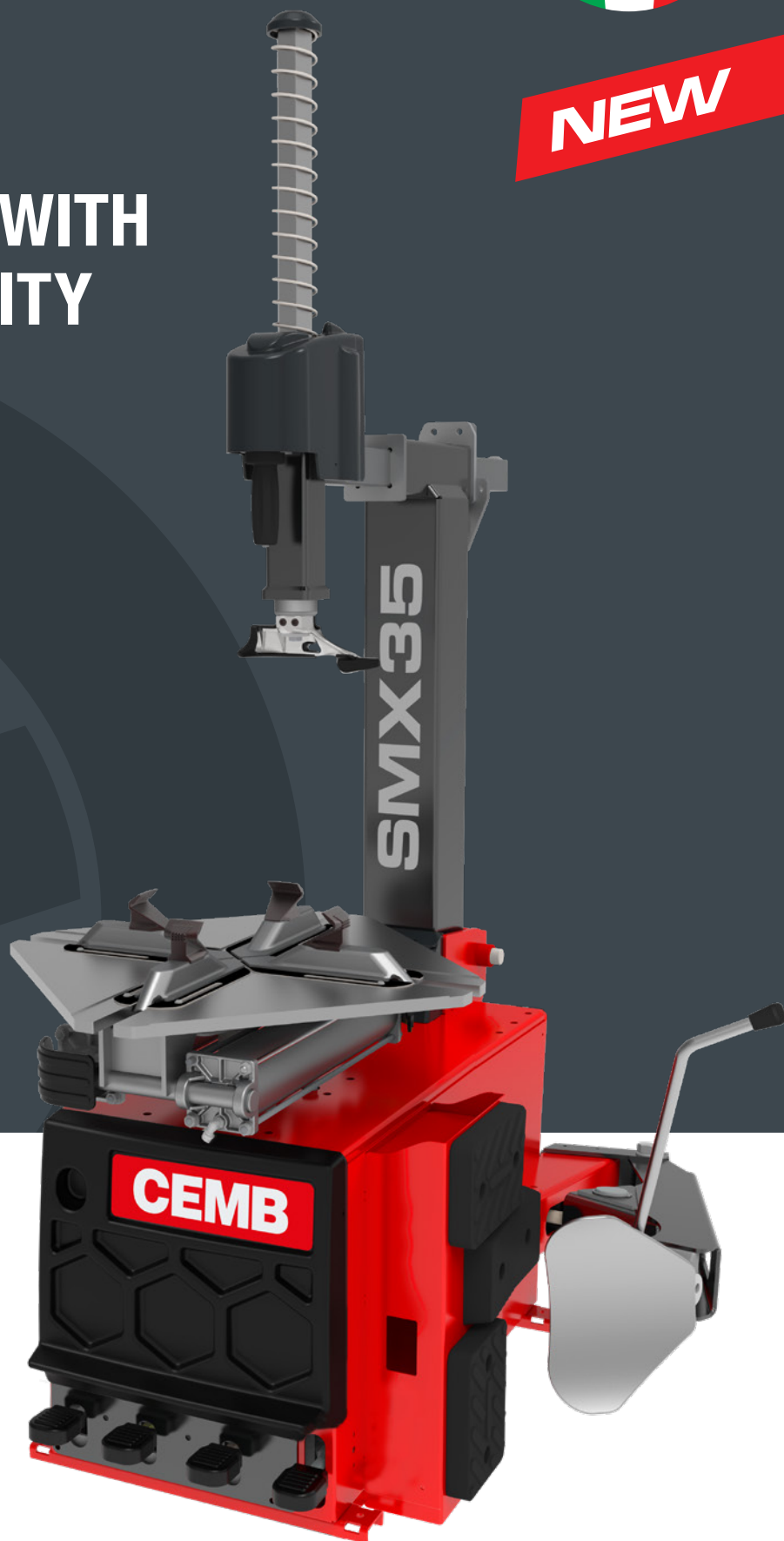

SMX35



- Automatic tyre changer with pneumatic **rear tilting post** granting the maximum rigidity to prevent rim damage.
- Smontagomme automatico con **palo ribaltabile pneumaticamente** che garantisce la massima rigidità per non danneggiare il cerchio.



- Professional **Tyre Pressure Gun with WIKA manometer**. For a tyre pressure up to max.10 bar.
- **Pistola professionale per gonfiaggio pneumatici con manometro WIKA**. Per una pressione di gonfiaggio fino a max. 10 bar.



- Self-centering square turntable to ease bead-breaking of the second tyre bead. Rim locking through opposed-jaws device (10"- 25" range), with 80 mm diameter cylinders, which guarantees an optimal grip on all types of rims. The special teeth of the jaws makes the locking from the inside wheel just as safe and effective. New swivel fitting (> speed).
- **Piatto autocentrante quadrato per agevolare il detallamento del secondo tallone**. Sistema di bloccaggio cerchio (**capacità da 10" a 25"**) a griffe contrapposte con cilindri di Ø 80 mm, che garantisce una forza di serraggio ottimale su tutti i tipi di cerchi. La particolare dentatura delle griffe rende il bloccaggio dall'interno ruota altrettanto sicuro ed efficace.



- **Bead breaker** with ergonomic arm to operate on wheels of 12" in width.
- **Stallonatore** ergonomico per operare su ruote da 12" di larghezza.



- Body with **removable pedal unit** for easy maintenance. Pedals positioned in line.
- Telaio con **pedaliera estraibile**, per facilitare le operazioni di manutenzione. Pedali posizionati in linea.



- Single speed **motor** (7 rpm).
- **Motore** a singola velocità (7 rpm).

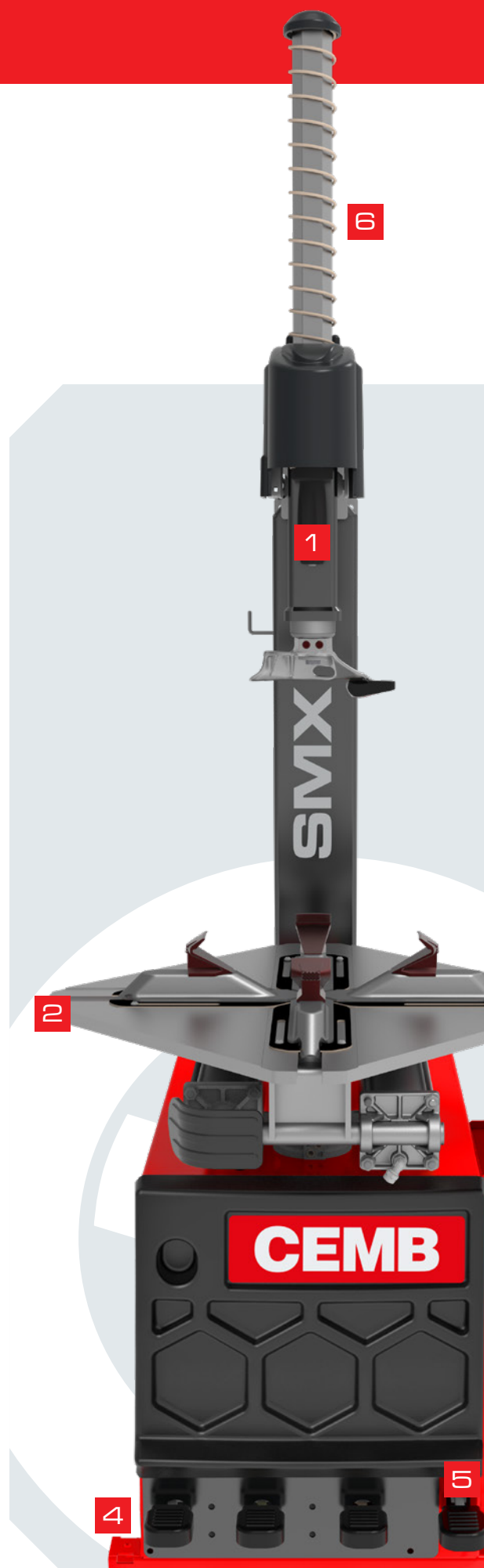

VERSIONS
ON REQUEST

VERSIONI
A RICHIESTA



TI-VERSION

Version with an effective inflation device for bead seating integrated in clamping jaws.

Versione dotata di efficace sistema di gonfiaggio tubeless incorporato nelle griffe, per l'intallamento dello pneumatico.

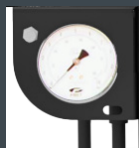

Version with pedal-operated inflating device, manometer and CE-certified inflation pressure limiter

Versione con dispositivo di gonfiaggio con azionamento a pedale, manometro e limitatore pressione di gonfiaggio a norme CE

6

- Reinforced base vertical 41 mm post structure and 50x50 mm horizontal arm grant maximum rigidity. Simultaneous vertical and horizontal arm locking system, vertical arm with spring return.
- Struttura palo rinforzata di 41 mm e braccio orizzontale avente dimensione 50x50 mm garantiscono la massima rigidità riducendo ogni possibile flessione. Sistema di bloccaggio simultaneo di asta verticale e braccio orizzontale con ritorno a molla dell'asta.

OPTIONAL ACCESSORIES ACCESSORI OPZIONALI

HPX-WS

- Professional side presser **HPX-WS** recommended to operate on particularly hard and large-sized Run-Flat and UHP Tyres.

Equipped with rim pressing cone, standard bead pressing roller arm, additional rotating bead pressing arm and bead lifting disc.

- Premitaltone laterale professionale **HPX-WS** raccomandato per operare su pneumatici Run-Flat e UHP particolarmente duri e di grandi dimensioni.

Dotato di cono di pressione del cerchio, braccio standard con rullo pressore, premitallone aggiuntivo rotante e disco di sollevamento.

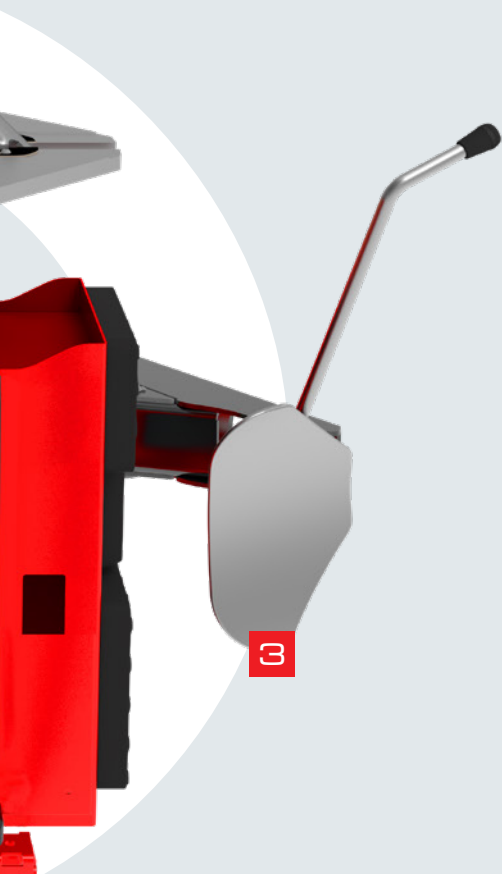

3



STANDARD ACCESSORIES - ACCESSORI STANDARD



Bead lever
Leva



Front head protection (x2)
Protezione frontale utensile (x2)



Rear head protection (x2)
Protezione ala utensile (x2)

OPTIONAL ACCESSORIES - ACCESSORI OPZIONALI



Wheel Lift
Sollevatore



Roller board
Kit rulliera



Tubeless inflation system
Sistema di gonfiaggio TI



4 jaws ALU protection kit
Kit 4 pezzi protezioni ALU per griffe



Bead breaker blade protection
Protezione paletta



Run Flat clamp
Pinza Run Flat



Michelin approved professional tire inflation gun
Pistola professionale per gonfiaggio pneumatici
omologata Michelin



Jaws for motorcycle wheels 14" ÷ 24"
Kit griffe moto 14" ÷ 24"



Jaws for scooter wheels 8" ÷ 14"
Kit griffe scooter 8" ÷ 14"

TECHNICAL DATA - DATI TECNICI

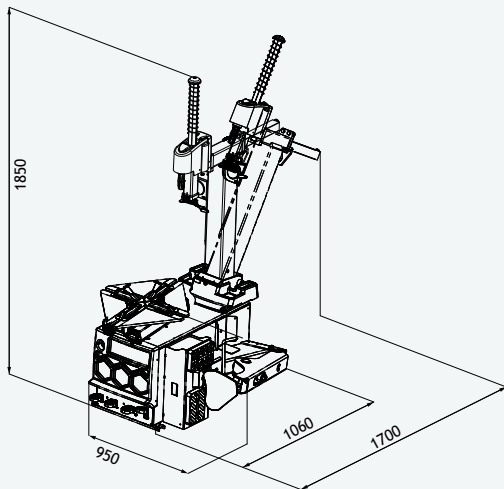

Clamping capacity	Capacità di bloccaggio	10" ÷ 25" (min ÷ max)
Internal clamping	Bloccaggio interno	12" - 25"
External clamping	Bloccaggio esterno	10" - 22"
Max wheel diameter	Diametro massimo ruota	1000 mm (39")
Max wheel width	Larghezza massima ruota	310 mm (12")
Bead breaker force	Forza stallonatore	15000 N
3-Phase motor	Potenza motore trifase	0,55 Kw 400V - 50/60Hz (1 speed)
Turntable speed	Velocità di rotazione	7 rpm (3ph - 1 speed)
Operating pressure	Pressione di esercizio	8 - 12 bar (116 - 174 psi)
Noise level	Livello di rumorosità	< 70 ± 3 dB (A)
Net weight	Peso Netto	210 kg



CEMB

BALANCING MACHINES

CEMB S.p.A.

Via Risorgimento, 9
23826 Mandello del Lario (LC) - Italy
www.cemb.com



Garage equipment division
CEMB - ITALY
Plant and Training Center
Phone +39 0341 706111
garage@cemb.com

CEMB USA - BL Systems Inc.
2873 Ramsey Road
Gainesville, GA 30501 - USA
Phone +001 678 717 1050
Fax +001 678 717 1056
sales@cemb-usa.com

All the data and features mentioned in this catalogue are purely for information and do not constitute any commitment on the part of our company, which reserves the right to make any and all alterations it may consider suitable without notice.